

HAURATON projects...



 Mandalika Street Circuit, Lombok, Indonesia



 Data Ran Merdeka in Kuala Lumpur, Malaysia

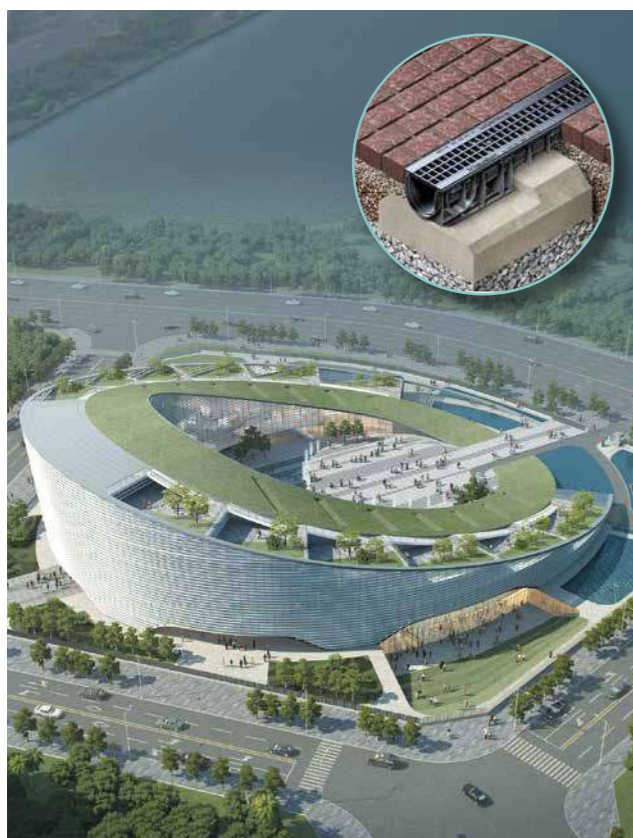

 Viettel Telecommunication Headquarter Hanoi, Vietnam



 Kuantan Port, Malaysia



HAURATON
surface drainage
channel



About **HAURATON**

4



Project applications
for drainage systems

16



Problems with In-Situ Channel vs. Benefits with HAURATON drainage solutions

6



RECYFIX PRO
Corrosion-free linear drainage for private and public areas.

18



Evolution of surface drainage systems

8

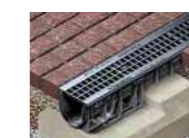

RECYFIX STANDARD
Linear drainage channels for public and commercial areas.

22



Characteristics of a drainage system & **HAURATON** product range

10



SLOTTED CHANNELS
Slotted channels for design-sensitive applications.

28



Your benefits with **RECYFIX** Channels

12



RECYFIX NC
Highly stable and lightweight - linear drainage made of PP for Civils engineering.

34



Load Classes

14



Additional products

40

Welcome to one of the worldwide leaders in drainage

Locations and partners all over the world



Your contact at Hauraton



From left to right: Daniel Schirm, Kathrin Sarnes, Rebecca Weiler, Michael Unger, Liesa Ziesemer, Francis Cheng, Wanli Zhao

HAURATON Global Page

Navigation: Application Areas, References, Our Drainage Systems, Hydraulic Software, About us

Hero Image: Drainage solutions from Hauraton

Key Features:

- Easy & quick installation:** Easy processing and installation & low long term maintenance costs
- High quality materials:** RECYTIX recycled composite channels: Shatterproof, durable & corrosion-resistant
- Hydraulically efficient:** Our channels drain extensive areas even in heavy rainfall

Application areas for Hauraton products: Our drainage channels are used in many Asian infrastructure sectors: from large-scale projects such as airports or race tracks to the drainage of container terminals and ports to the heavy duty drainage of warehouses & distribution centres.

Smart Cities | **Airport drainage**

Overview of trench drain systems: Heavy rainfall, climate changes and unpredictable weather patterns are impacting the way we control surface water. Professional drainage trench systems are becoming an important element for groundwork infrastructure. These systems are designed to quickly and effectively remove surface water from a variety of application areas to help prevent flooding or standing water.



Or on our website at www.global.hauraton.com/asia/

Problems with In-Situ Channels

General problems of in-situ channels:

- poor quality and durability → on site produced concrete often do not fulfil highest quality standards compared to factory made products and so often fail after a short time (e. g. cracks in concrete occur or breakdown of system happens)
- no traffic-secure solution → neither channel nor grating / cover could be proofed for requested loading capacity



Low security:

- unsecured gratings / covers → gratings / covers do not have any fixing with lower part.
- risk of injury → bigger slots are dangerous for pedestrians



Unpleasant optical appearance:

- cracks in concrete → cracks start to destroy the channel / cover step by step and do not look good
- rusted gratings → cheap ductile iron gratings tend to rust immediately

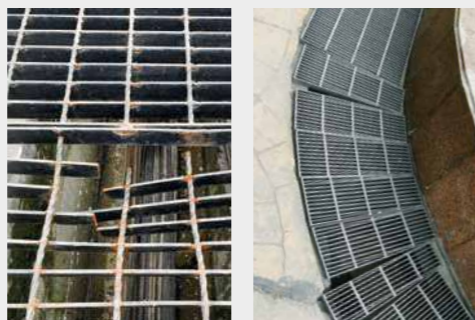

Higher effort and costs for installation:

- time-consuming and costly installation → higher cost on formwork, leveling and finishing is required



Benefits with HAURATON drainage solutions

Solution for in-situ channels:

- + pre-fabricated products are produced with high performance material and fulfill highest quality standards
- + additionally these systems fulfill EN 1433 and have a standard product guarantee



100% corrosion-free

Solution for high security:

- + gratings are locked securely with locking handle or bolts or are built in a monolithic way
- + slot openings are in a size that are safe for all kind of traffic users



Solution for a nice visual appearance:

- + due to high quality material and production technology all products are durable and look nice over a long time
- + gratings are available in different materials and designs for an attractive appearance

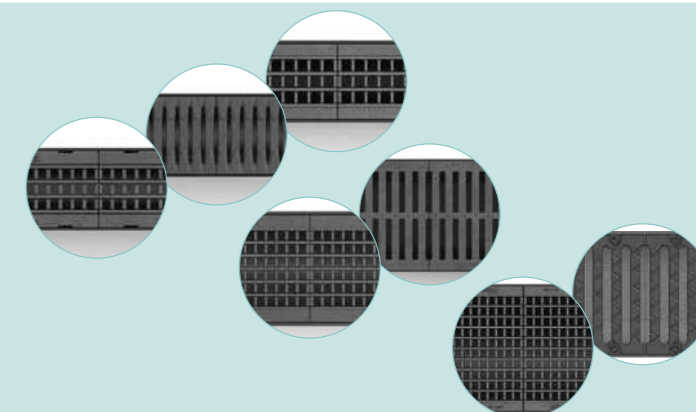

Solution for low effort and costs to install:

- + installation of prefab systems can be done much quicker and with less concrete surrounding



Evolution of surface drainage systems



Basic Channel

The world's first known urban waste water system appeared in Asia (LOTHAL) around 2600 BC.



In-Situ Channel

In-Situ Channel are simple systems cast from concrete on site, with a basic grating installed across the opening.



Modern System

RECYFIX - THE ALL-IN-ONE SOLUTION: A complete, modular linear drainage system to collect surface rainwater and stormwater with a prefabricated product: A channel (trench/U-drain) and grating fixed with a locking system.

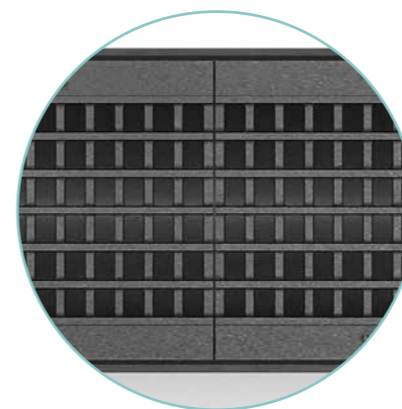

GUGI ductile iron gratings

Mesh width: 15 x 25 mm

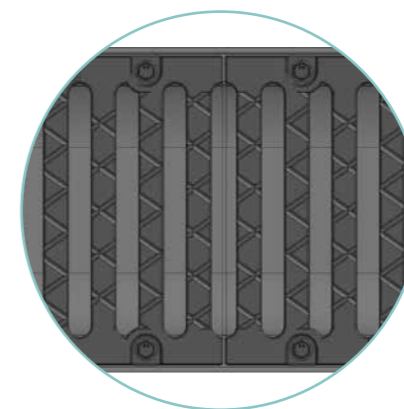

Ductile iron slotted gratings

Slot width: 18 mm

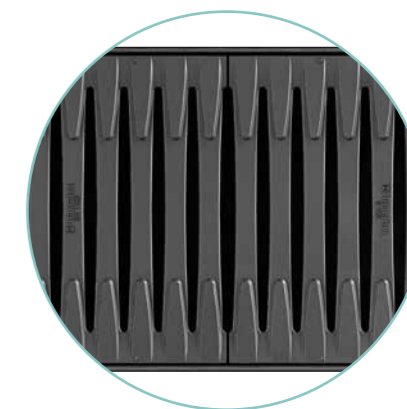

FIBRETEC Slotted gratings, composite material

Bar distance: 9 mm

Characteristics of a drainage system. How to choose the right product?

1. Project application in Classes

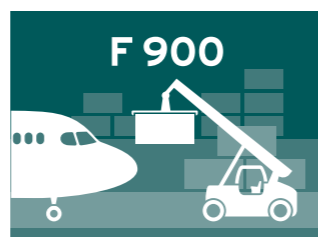
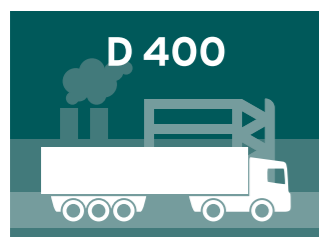
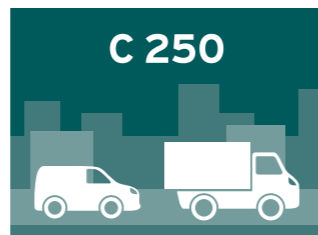
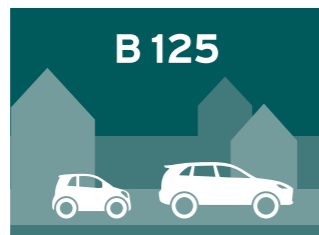
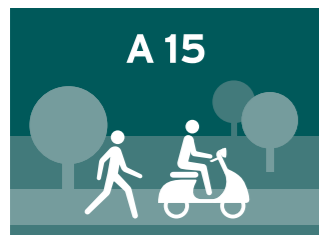

2. Hydraulic software

Drainage area depths in dependence on the line length of **RECYFIX®** channels



With a few information on area to be drained such as length, width and surface layer plus the rain intensity, with the Hauraton Hydraulic-App the best system from hydraulic purpose can be calculated.

A professional hydraulic calculation by our technical support team is available on request.

3. System

Drainage A complete drainage system consists of ...

- 1 Channels with gratings
- 2 End caps
- 3 Mud bucket
- 4 Trash box

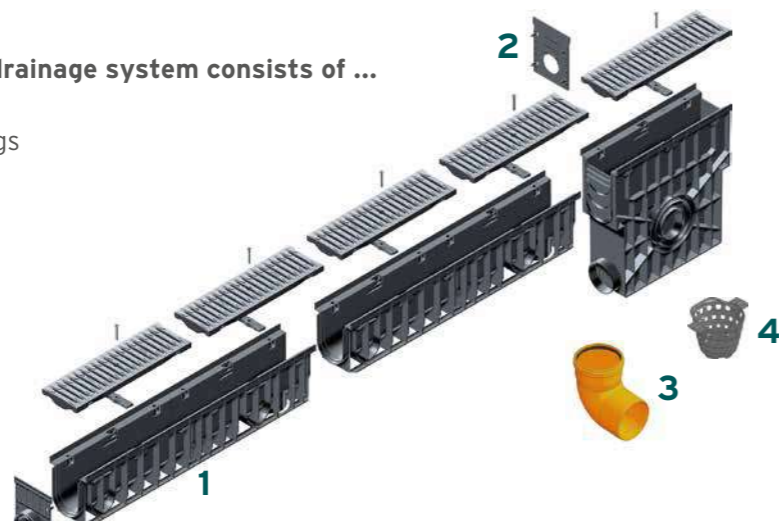

HAURATON product range

Applications	Nominal width					
	100	150	200	300	400	650
A 15	RECYFIX PRO		RECYFIX PRO	RECYFIX STANDARD		
B 125						
C 250	RECYFIX STANDARD / RECYFIX PRO / Slotted Channel	SLOTTED CHANNEL	RECYFIX STANDARD	RECYFIX STANDARD		
D 400	RECYFIX MONOTEC		RECYFIX MONOTEC		RECYFIX NC	
E 600	RECYFIX NC		RECYFIX NC	RECYFIX NC		
F 900	RECYFIX HICAP F	RECYFIX HICAP F	RECYFIX HICAP F	RECYFIX HICAP F		RECYFIX HICAP F

Further details on following product pages. **RECYFIX HICAP F** on request for project business

YOUR BENEFITS WITH **RECYFIX** CHANNELS

compared to local in-situ solutions

ANGLE HOUSING

- PP frame 20 x 20 mm acc. to DIN 1433 for additional flexibility and protection
- nibs to stop lateral movements
- inlaying gratings

= **PERFORMANCE ASSURED**



LOW WEIGHT ENSURES EASY HANDLING ON SITE

- much lighter than channels made of polymer/resin concrete
- easy transport and installation

= **TIME & COST SAVINGS**



HIGH RESISTANCE

- high resistance against UV-rays
- withstands high temperature differences
- for climate ranges from - 50 °C to + 80 °C and more

= **QUALITY ASSURED / LONGEVITY**



HIGH-GRADE MATERIAL

- **RECYFIX** - stable and almost unbreakable
- elastic and especially robust material
- withstands high loads and temperature differences in daily use
- 100 % recycled composite body (and also 100 % recyclable) → 100 % environmentally friendly
- 0 % water absorption
- smooth inner surface for superior flow characteristics
- non-conductive
- PP channel body can be cut, drilled and worked easily on site

= **QUALITY & PERFORMANCE ASSURED**



PRE-ASSEMBLED READY FOR INSTALLATION

- channel and grating = one part
- no spare parts
- easy handling in stock and on construction site
- cost-efficient transport

= **MORE PROFIT**



All-in-one Solution:
Trench/Channel and Grating
Drainage system

**50 % cost savings
on installation**

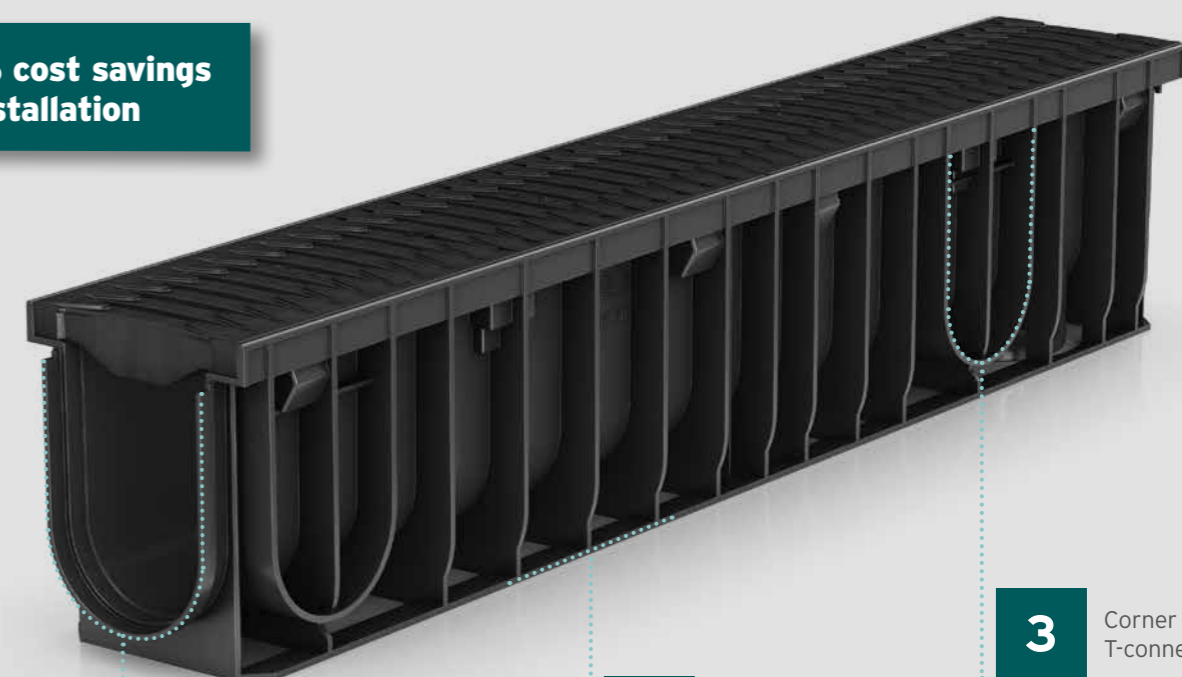

1

Tongue and groove connection & safety joint according to EN 1433

2

Anti floating

3

Corner and T-connection

100 % corrosion-free

Load Classes

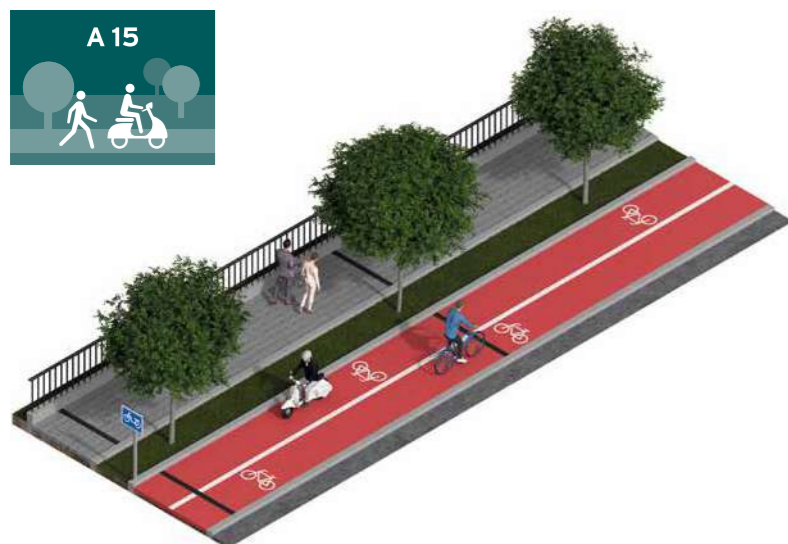

A 15

Traffic areas without car access

Possible applications

- Footpaths
- Cycle paths

Road users

- Pedestrians
- Bicycles
- Scooters
- Wheelchairs and walkers

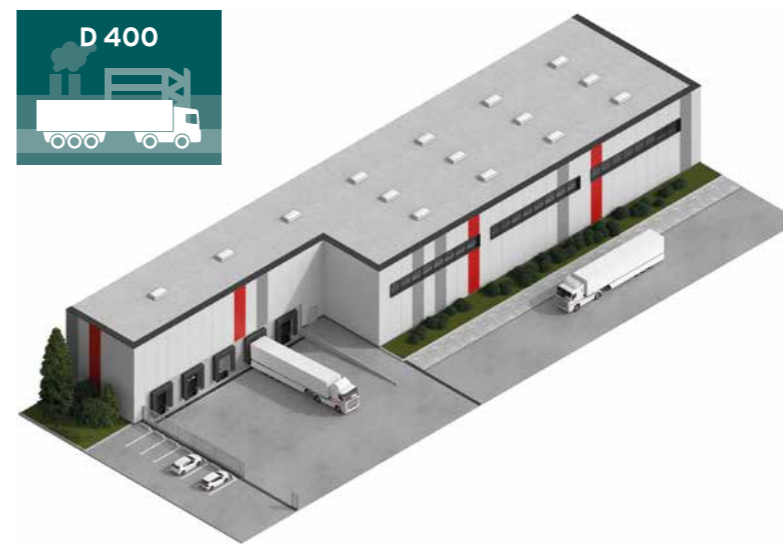
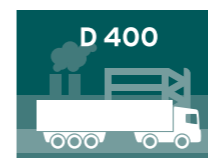

D 400

Roadways and streets (not for installation in the carriageway in motorways)

Possible applications

- Logistics centres
- Commercial areas
- Bus stations and bus terminals
- Petrol stations
- Lorry parking spaces

Road users

- Lorries
- Vans

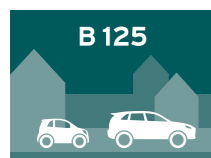

B 125

Traffic areas on private premises

Possible applications

- Driveways
- Courtyards
- Terraces
- Gardens

Road users

- Small and medium passenger cars
- SUVs



E 600

Industrial areas with loading and increased dynamics

Possible applications

- Industrial yards
- Loading areas

Road users

- Lorries
- Forklifts

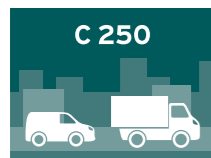

C 250

Public areas with light traffic and moderate frequency

Possible applications

- Public areas
- Car parks (e.g. supermarket, DIY store)
- Residential building
- Parks

Road users

- Small and medium-sized cars (optionally with trailer)
- SUVs (optionally with trailer)
- Lorries and vans
- Light trucks and motorhomes up to 7.5 t



F 900

Surfaces with extremely high wheel loads and dynamics

Possible applications

- Airports
- Ports
- Container terminals
- Race and test tracks

Road users

- Aeroplanes
- Reachstackers
- Racing cars

Dynamic forces and increased traffic frequency change the stress on drainage systems! If in doubt, choose a higher load class. If you have any questions, our experts will be happy to advise you on the selection of the right system!

Project applications for drainage systems

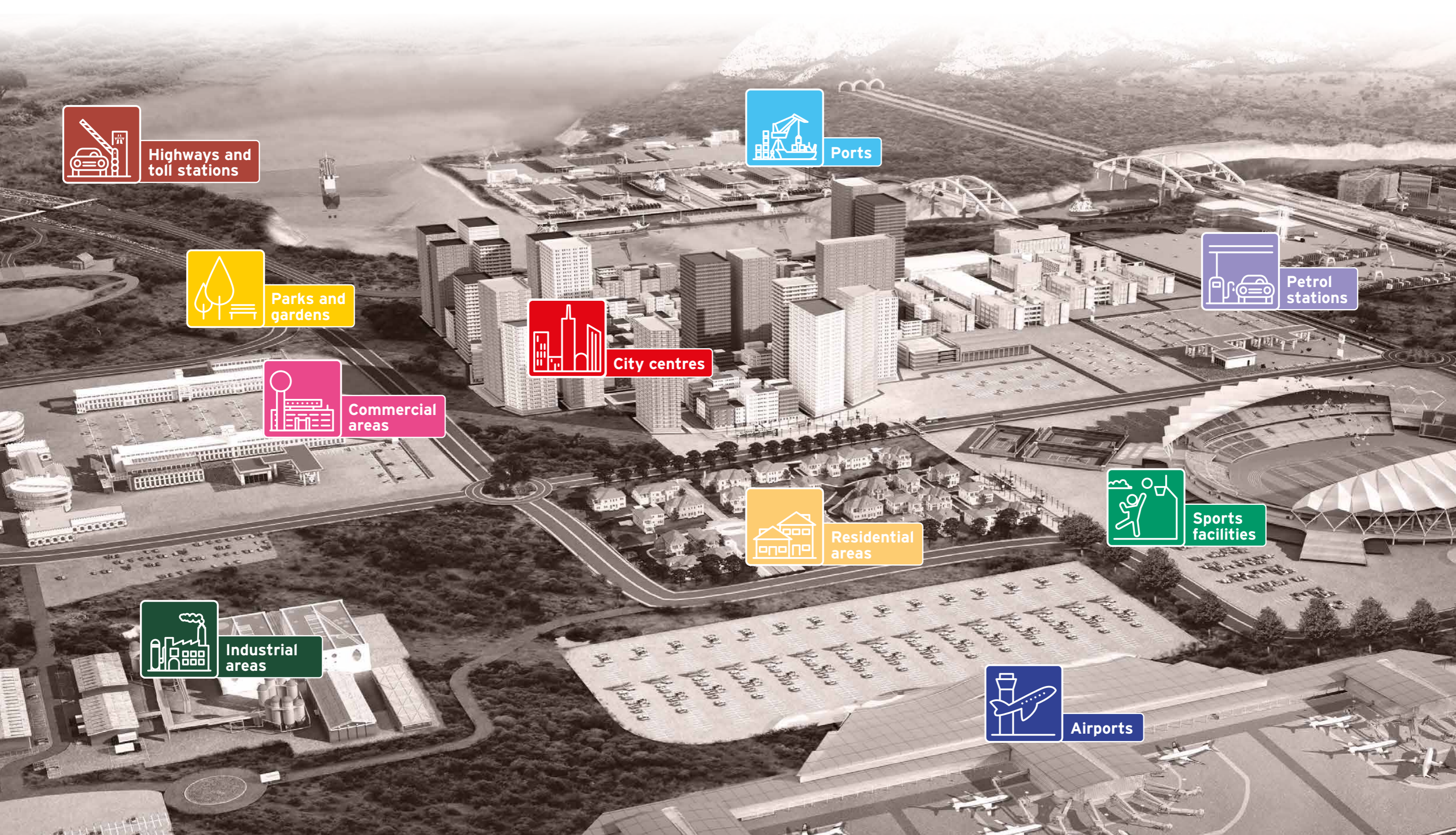

Highways and toll stations

Parks and gardens

Commercial areas

Industrial areas

Ports

City centres

Residential areas

Petrol stations

Sports facilities

Airports

RECYFIX PRO

Corrosion-free drainage system for private and public areas.

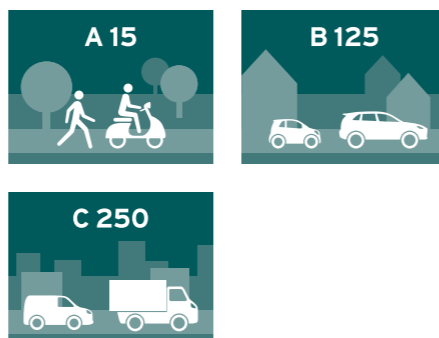

**- Market squares
- Public areas
- Private areas**

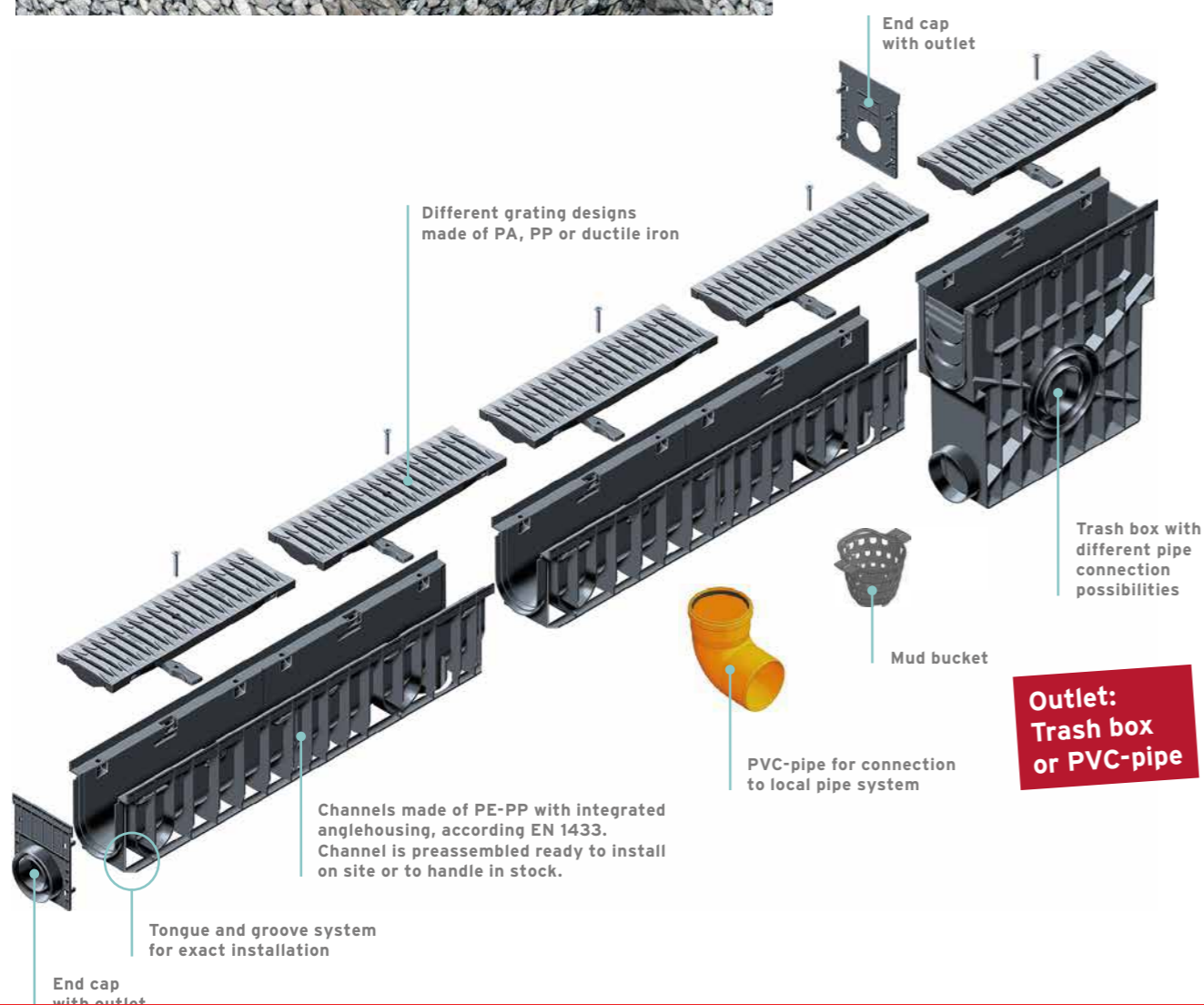

Grace Hill, High-rise, Seoul, South Korea



RECYFIX®PRO 100

Combi article

RECYFIX®PRO 100, class B 125

Type 020 with GUGI-Grating made of PA-GF, MW 15/25, black, locked

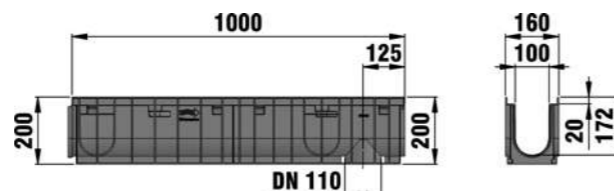

	Length mm	Width mm	Height mm	Drainage cross-sect. cm ²	Intake cross-sect. cm ² /m	Weight kg	Item No.
Type 01 with GUGI-Grating made of PA-GF, MW 15/25, black, locked	1000	160	150	92	444	4,3	47035
Type 010 with GUGI-Grating made of PA-GF, MW 15/25, black, locked	1000	160	200	142	444	4,7	47040
Type 020 with GUGI-Grating made of PA-GF, MW 15/25, black, locked	1000	160	250	192	444	5,5	48623
Type 75 with GUGI-Grating made of PA-GF, MW 15/25, black, locked	1000	160	75	35	444	2,9	47032
Type 95 with GUGI-Grating made of PA-GF, MW 15/25, black, locked	1000	160	95	55	444	3,6	47033

RECYFIX®PRO 100, class C 250

Type 01 with FIBRETEC slotted grating, SW 9 mm, black

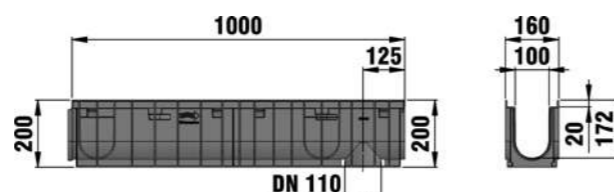

	Length mm	Width mm	Height mm	Drainage cross-sect. cm ²	Intake cross-sect. cm ² /m	Weight kg	Item-No. galvanised
Type 01 with FIBRETEC slotted grating, SW 9 mm, black	1000	160	150	92	372	4,6	47055
Type 010 with FIBRETEC slotted grating, SW 9 mm, black	1000	160	200	142	372	4,9	47060
Type 020 with FIBRETEC slotted grating, SW 9 mm, black, locked	1000	160	250	192	372	5,8	48625
Type 75 with FIBRETEC slotted grating, SW 9 mm, black	1000	160	75	35	372	3,4	47062
Type 95 with FIBRETEC slotted grating, SW 9 mm, black	1000	160	95	55	372	3,7	47063

RECYFIX®PRO 200

RECYFIX®PRO 200, class B 125

Type 010 with FIBRETEC slotted grating, SW 9 mm, black, locked

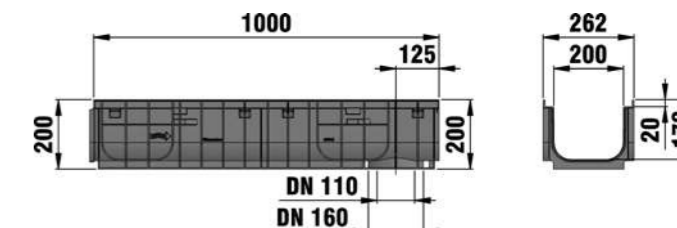

	Length mm	Width mm	Height mm	Drainage cross-sect. cm ²	Intake cross-sect. cm ² /m	Weight kg	Item No.
Type 010 with FIBRETEC slotted grating, SW 9 mm, black, locked	1000	262	200	294	656	8,3	47246
Type 115 with FIBRETEC slotted grating, SW 9 mm, black, locked	1000	262	115	150	656	7,0	47233



RECYFIX STANDARD

Linear drainage channels for public and commercial area.

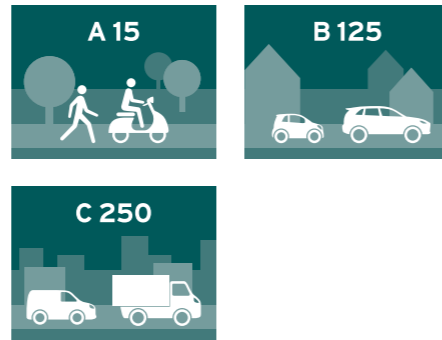

- Market squares
- Public areas
- Private areas

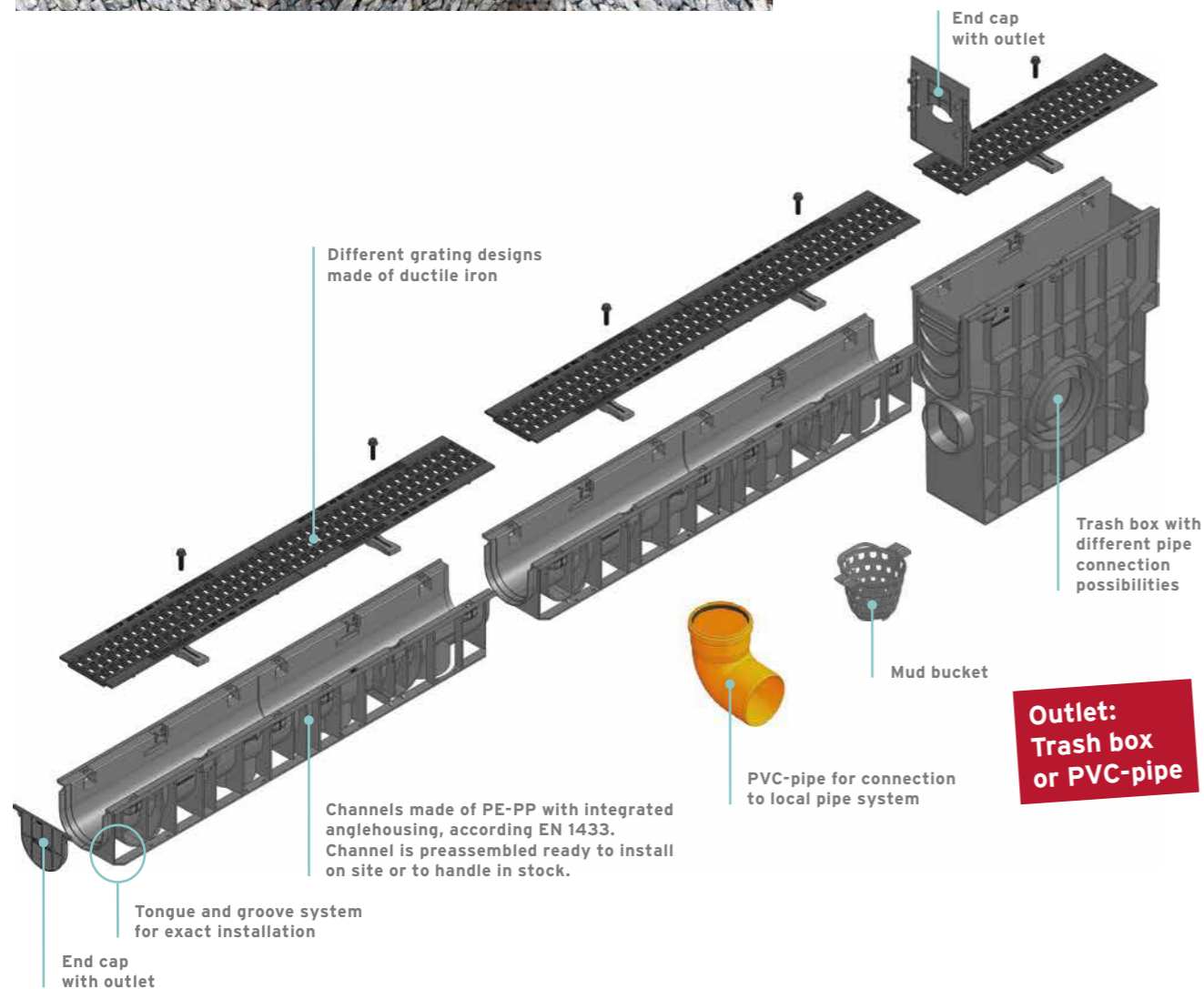

German Embassy, Hanoi, Vietnam



Condominium Suites Project Parque Norm Marque in Bangkok, Thailand

RECYFIX®STANDARD 100

Combi article

RECYFIX®STANDARD 100, class C 250

Type 01 with GUGI-Ductile iron mesh grating MW 15/25, black, locked

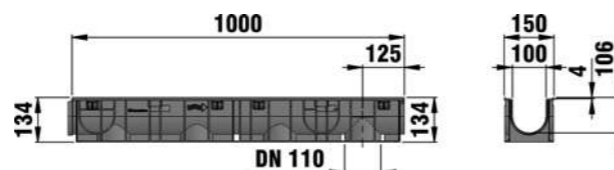
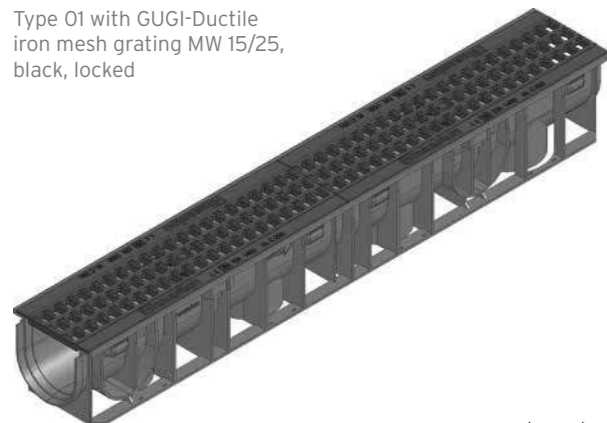

	Length mm	Width mm	Height mm	Drainage cross-sect. cm ²	Intake cross-sect. cm ² /m	Weight kg	Item No.
Type 01 with GUGI-Ductile iron mesh grating MW 15/25, black, locked	1000	150	134	92	444	7,1	40234
Type 010 with GUGI-Ductile iron mesh grating MW 15/25, black, locked	1000	150	185	142	444	8,6	40299
Type 60 with GUGI-Ductile iron mesh grating MW 15/25, black, locked*	1000	150	60	35	444	5,4	40239
Type 80 with GUGI-Ductile iron mesh grating MW 15/25, black, locked*	1000	150	80	55	444	5,5	40253

* For frequently used areas we recommend FASERFIX KS Channels shallow (see CIVILS).
Type 60/type 80 with preformed outlet DN 70.

RECYFIX®STANDARD 200

Combi article

RECYFIX®STANDARD 200, class B 125

Type 010 with mesh grating MW 30/30 mm, galvanised, locked, 1,0 m

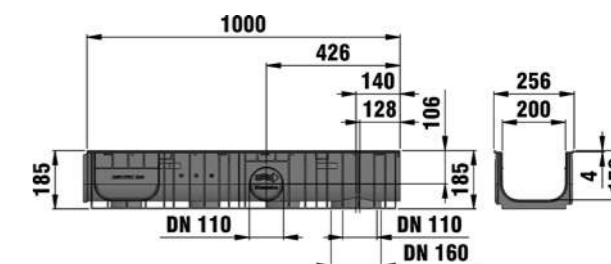
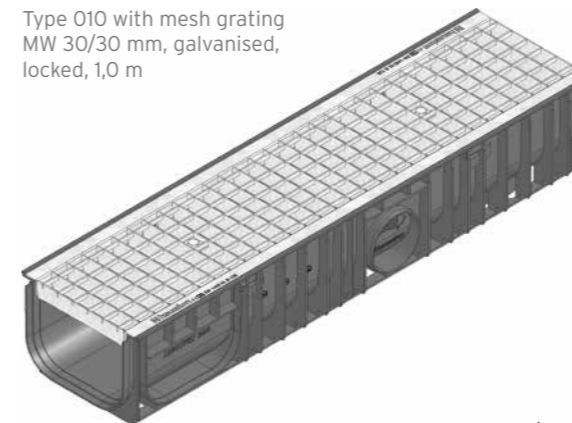

	Length mm	Width mm	Height mm	Drainage cross-sect. cm ²	Intake cross-sect. cm ² /m	Weight kg	Item No.
Type 010 with mesh grating MW 30/30 mm, galvanised, locked, 1,0 m	1000	256	185	290	825	15,4	40672

RECYFIX®STANDARD 200, class C 250

Type 010 with GUGI-Ductile iron mesh grating MW 15/25, black, locked

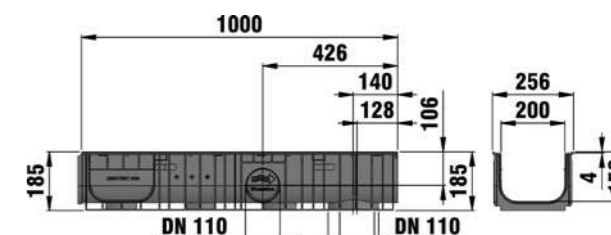
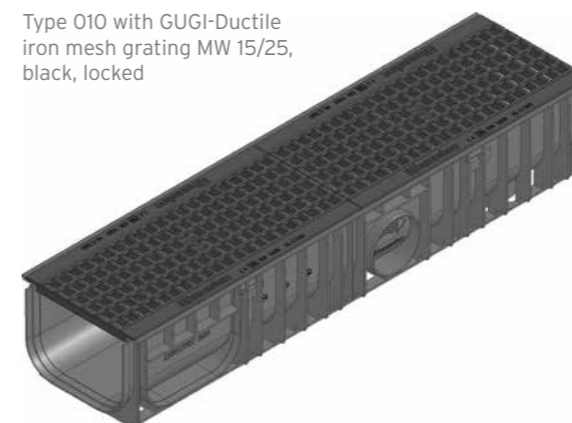

	Length mm	Width mm	Height mm	Drainage cross-sect. cm ²	Intake cross-sect. cm ² /m	Weight kg	Item No.
Type 010 with GUGI-Ductile iron mesh grating MW 15/25, black, locked	1000	256	185	290	825	15,4	40665
Type 020 with GUGI-Ductile iron mesh grating MW 15/25, black, locked	1000	256	235	366	825	15,8	40666
Type 100 with GUGI-Ductile iron mesh grating MW 15/25, black, locked	1000	256	100	150	825	14,1	40641

RECYFIX®STANDARD 300

Combi article

RECYFIX®STANDARD 300, class B 125

Type 01 with ductile iron grating, SW 2 x 127/18 mm, black, locked

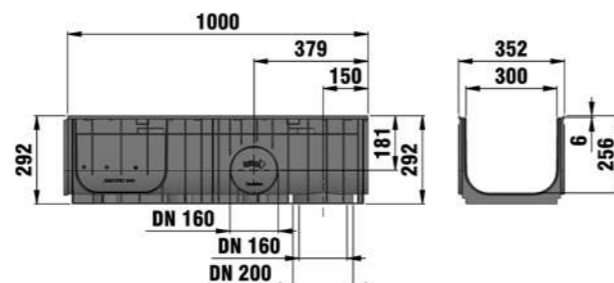
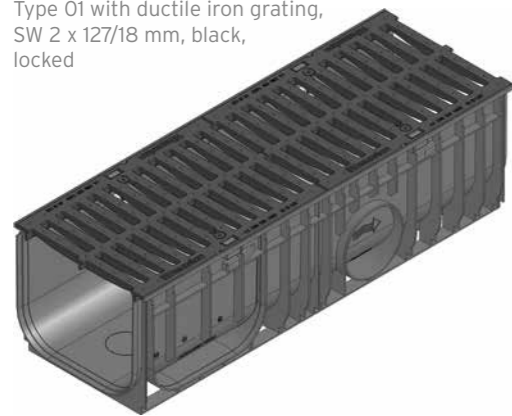

	Length mm	Width mm	Height mm	Drainage cross-sect. cm ²	Intake cross-sect. cm ² /m	Weight kg	Item No.
Type 01 with ductile iron grating, SW 2 x 127/18 mm, black, locked	1000	352	292	725	-	22,7	32864

RECYFIX®STANDARD



 Teega Residence - Iskandar, Puteri, Johor, Malaysia

RECYFIX®STANDARD 300, class C 250

Type 01 with GUGI-Ductile iron mesh grating, MW 15/25, black, locked

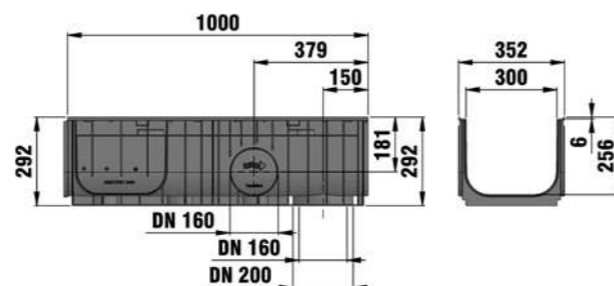
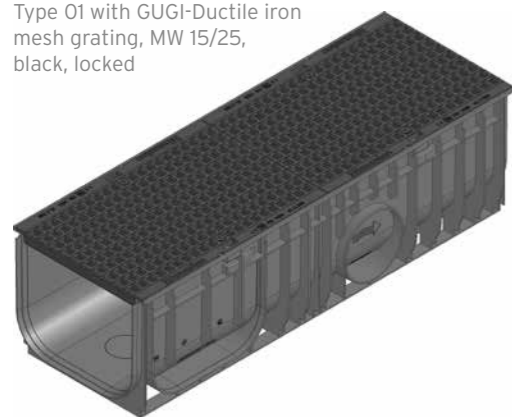

	Length mm	Width mm	Height mm	Drainage cross-sect. cm ²	Intake cross-sect. cm ² /m	Weight kg	Item No.
Type 01 with GUGI-Ductile iron mesh grating, MW 15/25, black, locked	1000	350	292	725	1385	29,1	40870
Type 010 with GUGI-Ductile iron mesh grating, MW 15/25, black, locked	1000	420	381	857	1385	33,20	40875



 University, Tsukuba, Japan

SLOTTED CHANNELS

SLOTTED CHANNELS for design-sensitive applications.

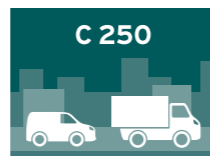

- Market squares
- Public areas
- Private areas

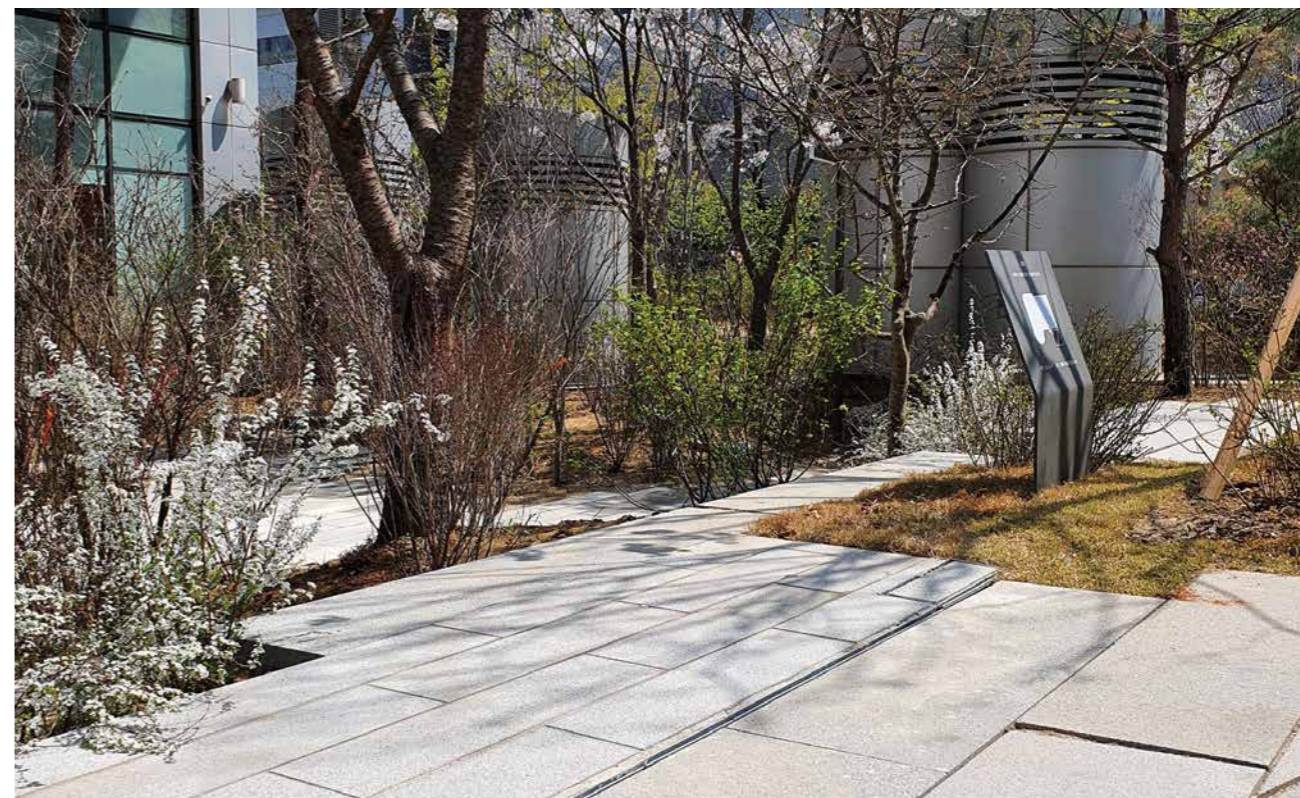

JTBC Television Network HG Company Premises, South Korea

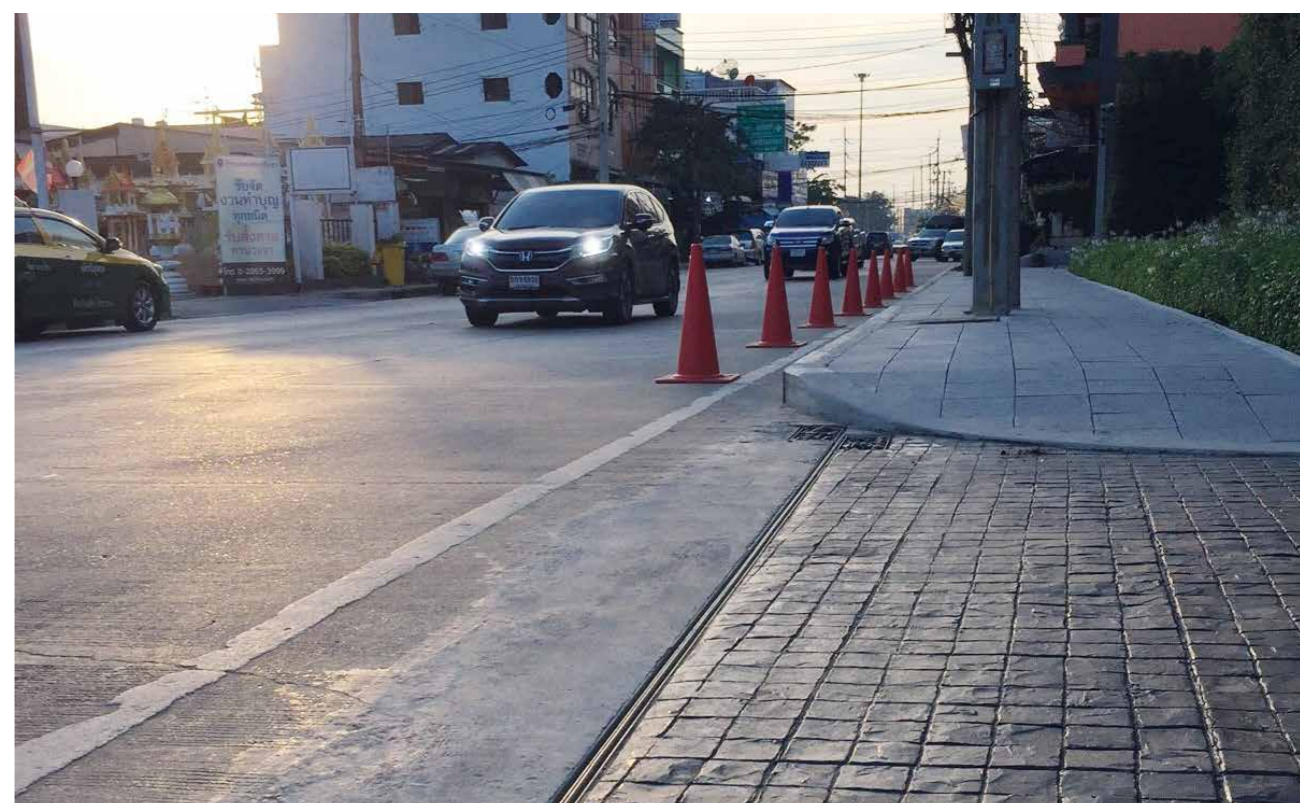
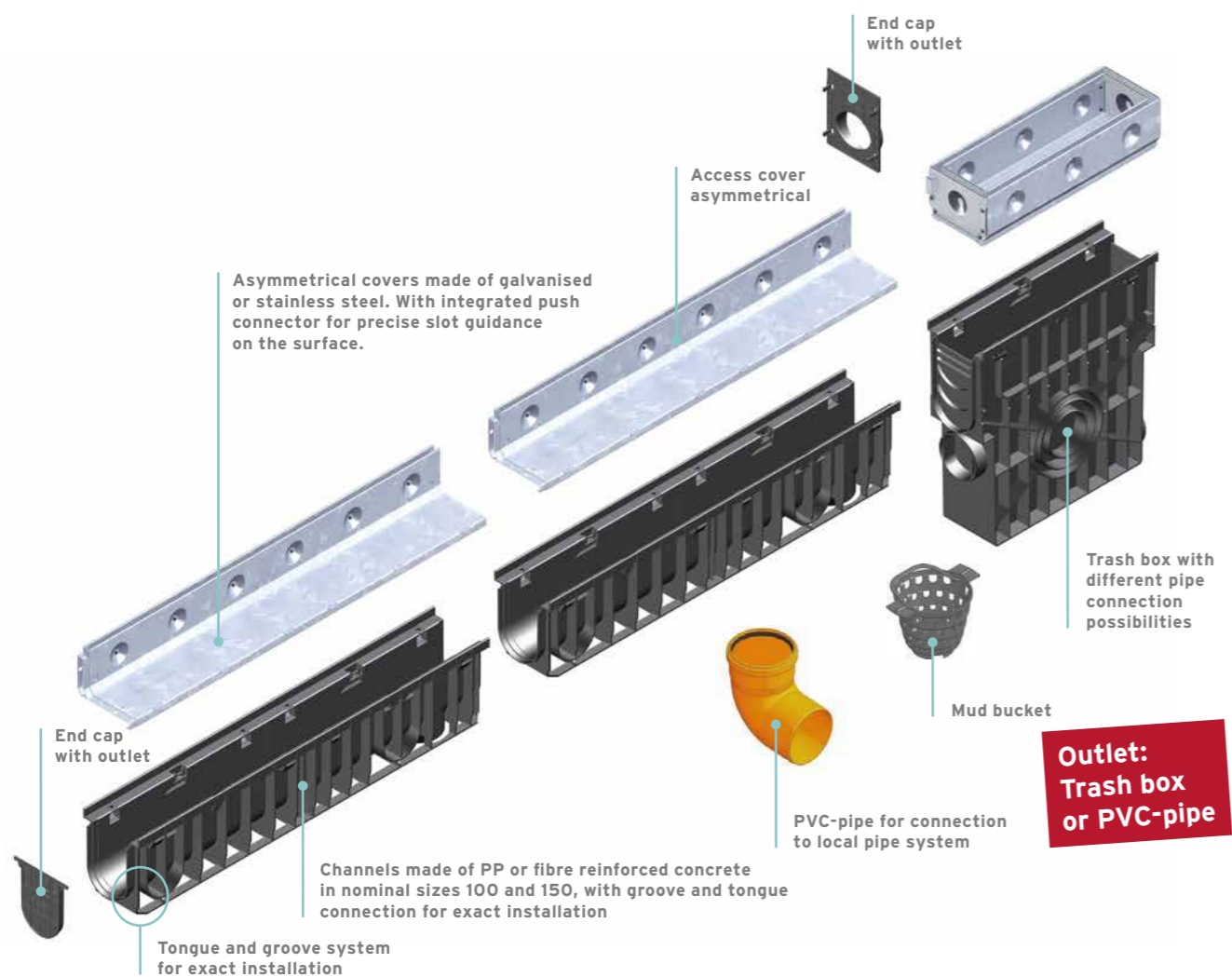

Tycoon Project in Bangkok, Thailand

SLOTTED CHANNEL 100

Channels

RECYFIX®PRO 100

Type 01

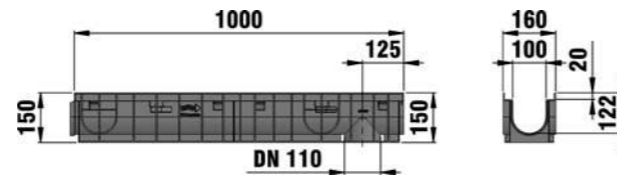
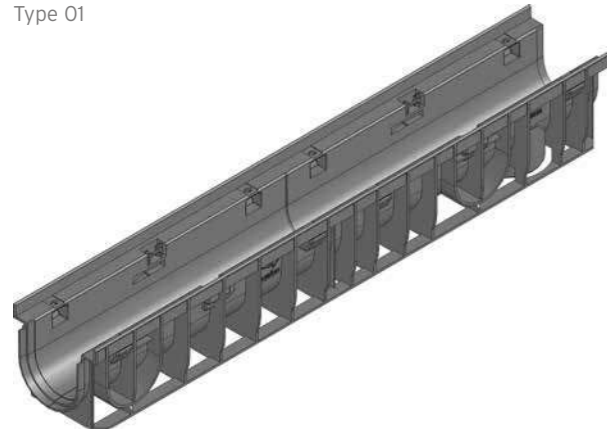

Type 010

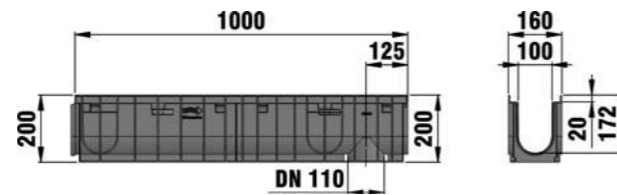
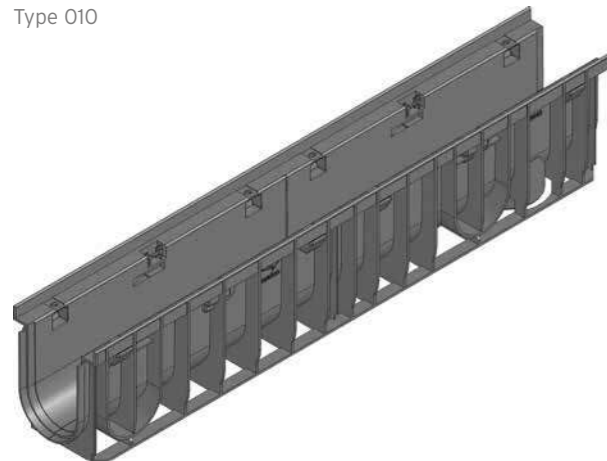

	Length mm	Width mm	Height mm	Drainage cross-sect. cm ²	Weight kg	Item No.
Type 01	1000	160	150	92	2,2	48600
Type 010	1000	160	200	142	2,7	48642
Type 020	1000	160	250	192	3,6	48620

SLOTTED CHANNEL 100

Gratings

Slotted Covers 100, neck height 160, class C 250



Asymmetrical SW 12 mm, 1,0 m



Asymmetrical SW 12 mm, 0,5 m



Access cover asymmetrical, SW 12 mm, 0,5 m

	Length mm	Width mm	Height mm	Intake cross-sect. cm ² /m	Weight kg	Item-No. galvanised	Item-No. stainless steel
Asymmetrical SW 12 mm, 1,0 m	1000	156	126	120	6,02	32247	32248
Asymmetrical SW 12 mm, 0,5 m	500	156	126	120	3,19	32277	32278
Access cover asymmetrical, SW 12 mm, 0,5 m	500	163	126	-	5,22	32303	32304
Asymmetrical, duo slot, SW 2 x 6 mm, 1,0 m	1000	156	126	120	8,31	32253	32254
Asymmetrical, duo slot, SW 2 x 6 mm, 0,5 m	500	156	126	120	4,20	32283	32284
Access cover asymmetrical, duo slot, SW 2 x 6 mm, 0,5 m	500	163	125	-	6,71	32746	32747

Bigger nominal sizes and individual neck heights as tailor-made production possible for more than 30 m. The quality of stainless steel material corresponds to CNS 1.4301.

Slotted Covers 100, neck height 160, class C 250



Asymmetrical, SW 12 mm



Asymmetrical, SW 12 mm

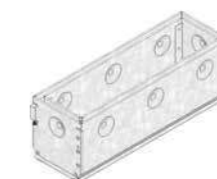

Access cover asymmetrical, SW 12 mm

	Length mm	Width mm	Height mm	Intake cross-sect. cm ² /m	Weight kg	Item-No. galvanised	Item-No. stainless steel
Asymmetrical, SW 12 mm	1000	156	181	-	7,2	32249	32250
Asymmetrical, SW 12 mm	500	156	181	-	3,8	32279	32280
Access cover asymmetrical, SW 12 mm	500	163	181	-	6,9	32305	32306

Bigger nominal sizes and individual neck heights as tailor-made production possible for more than 30 m. The quality of stainless steel material corresponds to CNS 1.4301.

SLOTTED CHANNEL 150

Channels

RECYFIX®PRO 150

Type 01

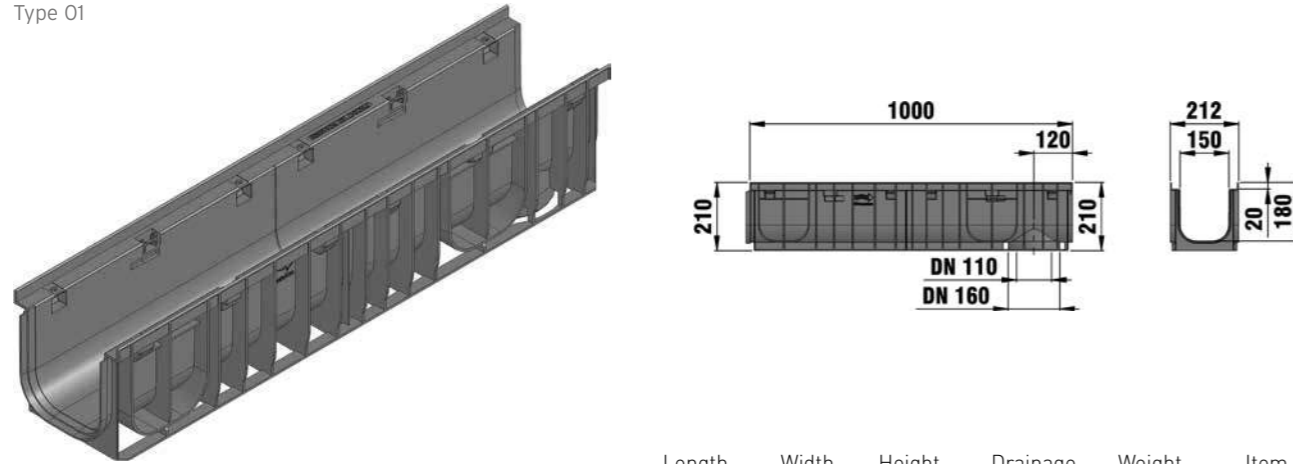

	Length mm	Width mm	Height mm	Drainage cross-sect. cm ²	Weight kg	Item No.
Type 01	1000	212	210	230	3,2	47100

Gratings

Slotted Covers 150, neck height 160, class C 250



Asymmetrical, SW 12 mm

Asymmetrical, SW 12 mm

Access cover asymmetrical,
SW 12 mm

	Length mm	Width mm	Height mm	Intake cross-sect. cm ² /m	Weight kg	Item-No. galvanised	Item-No. stainless steel
Asymmetrical, SW 12 mm	1000	206	181	-	2,2	32400	32401
Asymmetrical, SW 12 mm	500	206	181	-	3,8	32404	32405
Access cover asymmetrical, SW 12 mm	500	-	-	-	8,0	32731	32732

Bigger nominal sizes and individual neck heights as tailor-made production possible for more than 30 m.
The quality of stainless steel material corresponds to CNS 1.4301.

SLOTTED CHANNEL



Jui Residences Condo Residential Complex, Singapore



Samil Office Building - Seoul, South Korea

RECYFIX NC

Linear drainage channels for public and commercial area.

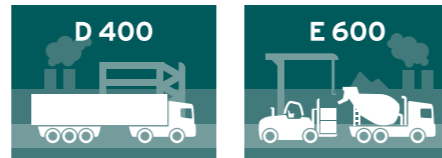

- Industrial yards
- Streets (alongside)
- Commercial areas



Tutong, petrol station, Brunei

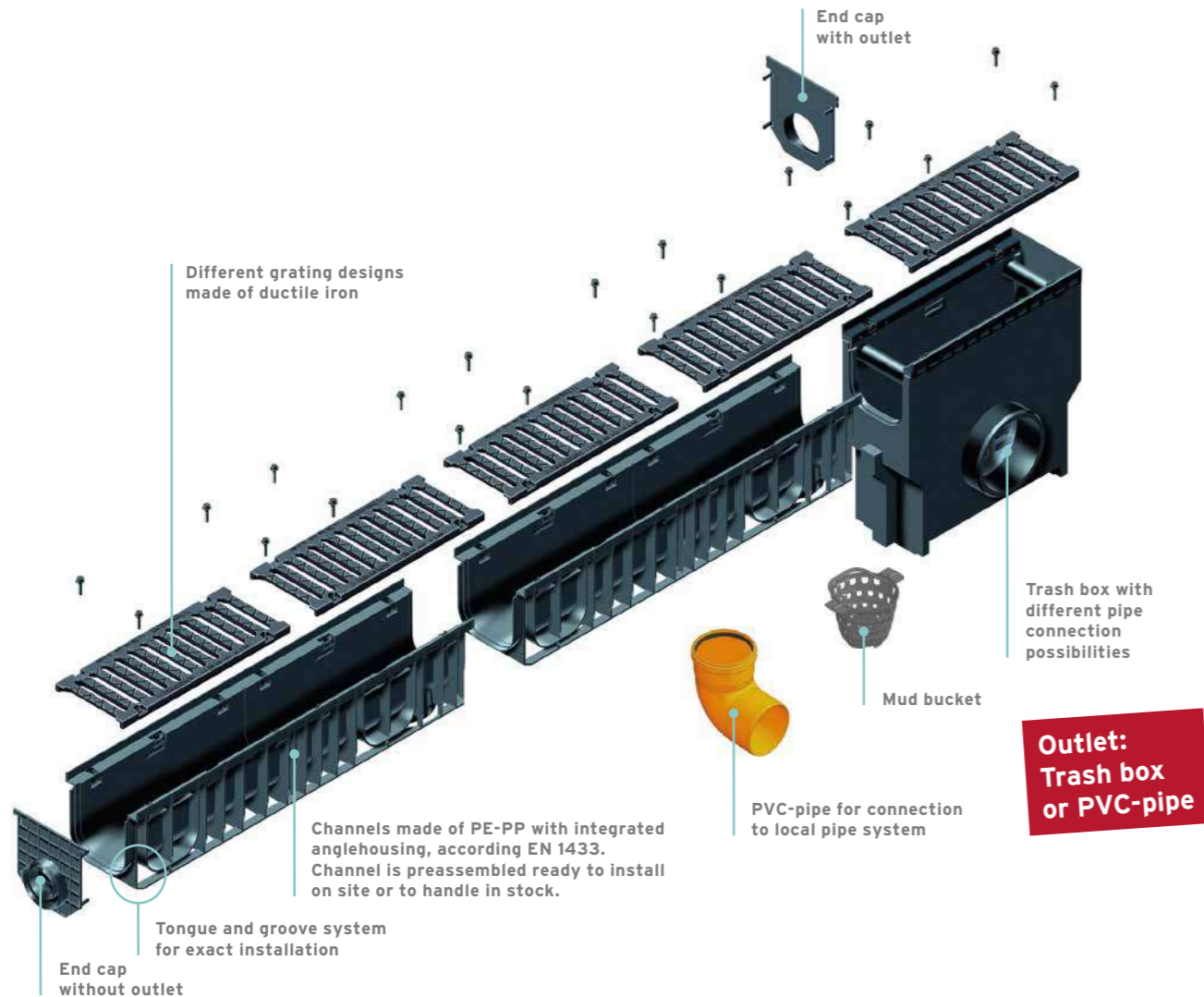

Sanwa Food Company - Office building, Osaka, Japan

RECYFIX®NC

Combi article

RECYFIX®NC 100, class E 600

Type 020 with ductile iron grating, SW 10, black, 8-fold bolted

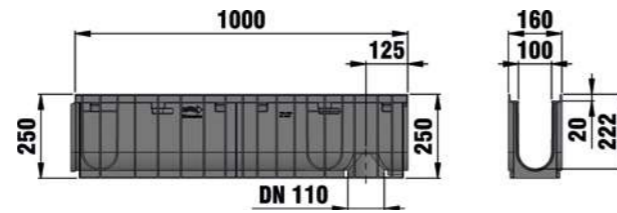
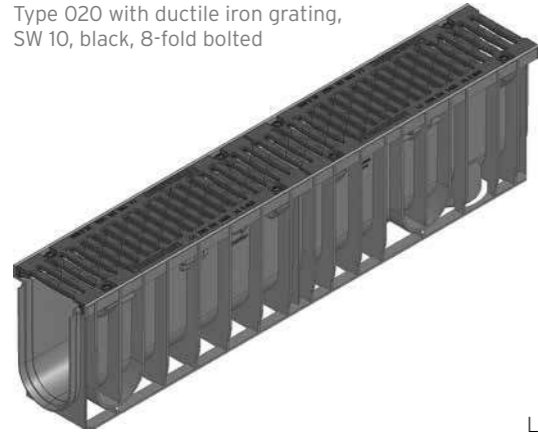

	Length mm	Width mm	Height mm	Drainage cross-sect. cm ²	Intake cross-sect. cm ² /m	Weight kg	Item No.
Type 01 with ductile iron grating, black, SW 10 mm, 8-fold bolted	1000	160	150	92	427	10,7	48770
Type 010 with ductile iron grating, black, SW 10 mm, 8-fold bolted	1000	160	200	142	427	11,6	48772
Type 020 with ductile iron grating, black, SW 10 mm, 8-fold bolted	1000	160	250	192	427	12,5	48776
Type 75 with ductile iron grating, black, SW 10 mm, 8-fold bolted	1000	160	75	35	427	10,2	48774

RECYFIX®NC 200, class E 600

Type 010 with ductile iron grating, black, SW 18 mm, 8-fold bolted

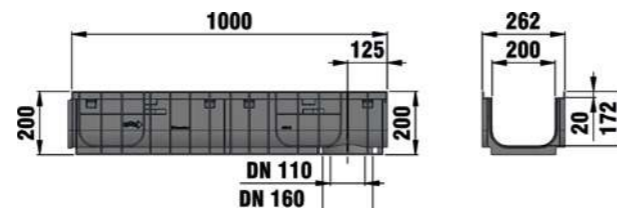
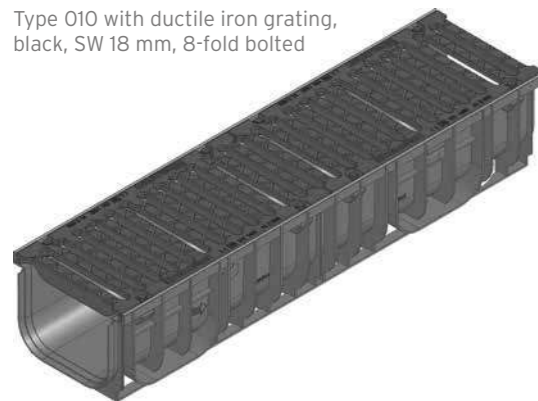

	Length mm	Width mm	Height mm	Drainage cross-sect. cm ²	Intake cross-sect. cm ² /m	Weight kg	Item No.
Type 010 with ductile iron grating, black, SW 18 mm, 8-fold bolted	1000	262	200	294	936	20,8	49572

RECYFIX®NC

RECYFIX®NC 300, class E 600

Type 010 with ductile iron grating, black, SW 18 mm, 8-fold bolted

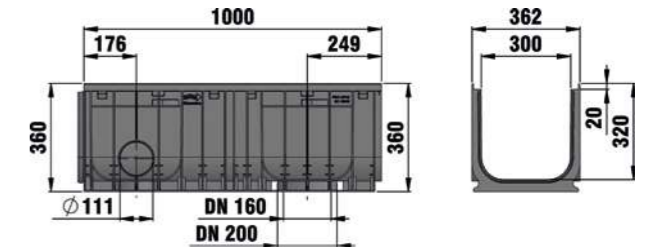
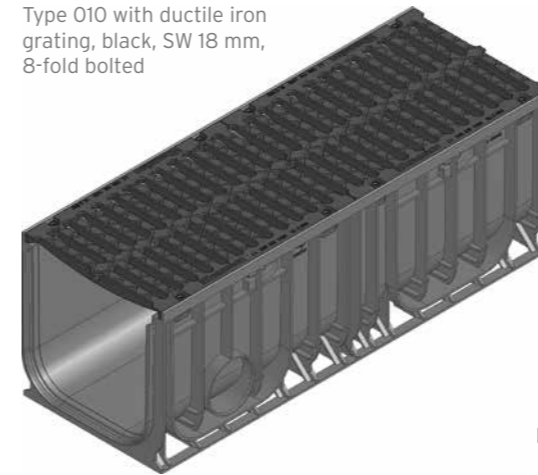

	Length mm	Width mm	Height mm	Drainage cross-sect. cm ²	Intake cross-sect. cm ² /m	Weight kg	Item No.
Type 010 with ductile iron grating, black, SW 18 mm, 8-fold bolted	1000	362	360	873	1293	35,0	49872

RECYFIX®NC 400, class D 400

Type 010 with ductile iron grating, black, SW 18 mm, 8-fold bolted

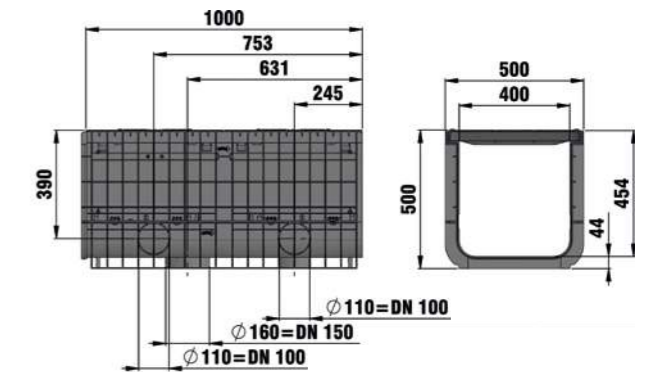
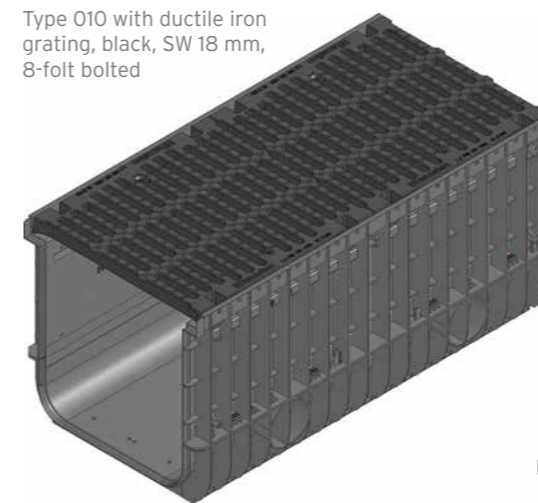

	Length mm	Width mm	Height mm	Drainage cross-sect. cm ²	Intake cross-sect. cm ² /m	Weight kg	Item No.
Type 010 with ductile iron grating, black, SW 18 mm, 8-fold bolted	1000	500	500	1640	1753	57,2	42421

RECYFIX POINT

Linear drainage channels for public and commercial area.

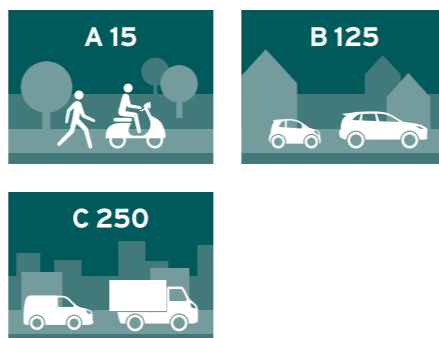

- Market squares
- Public areas
- Private areas

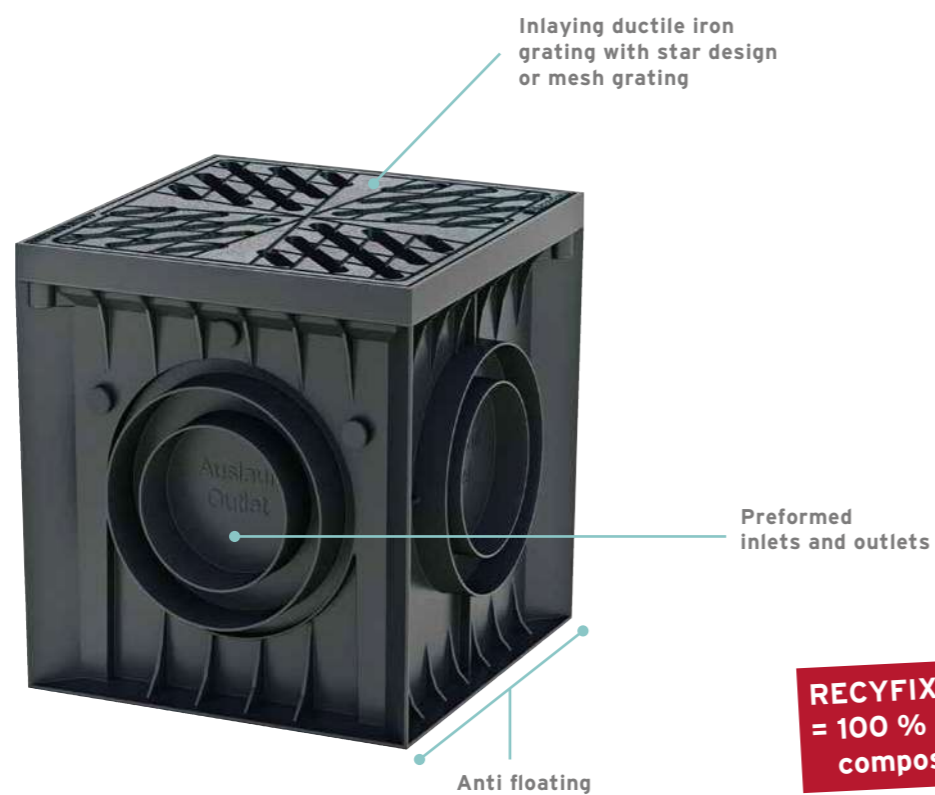

RECYFIX material = 100 % recycled composite

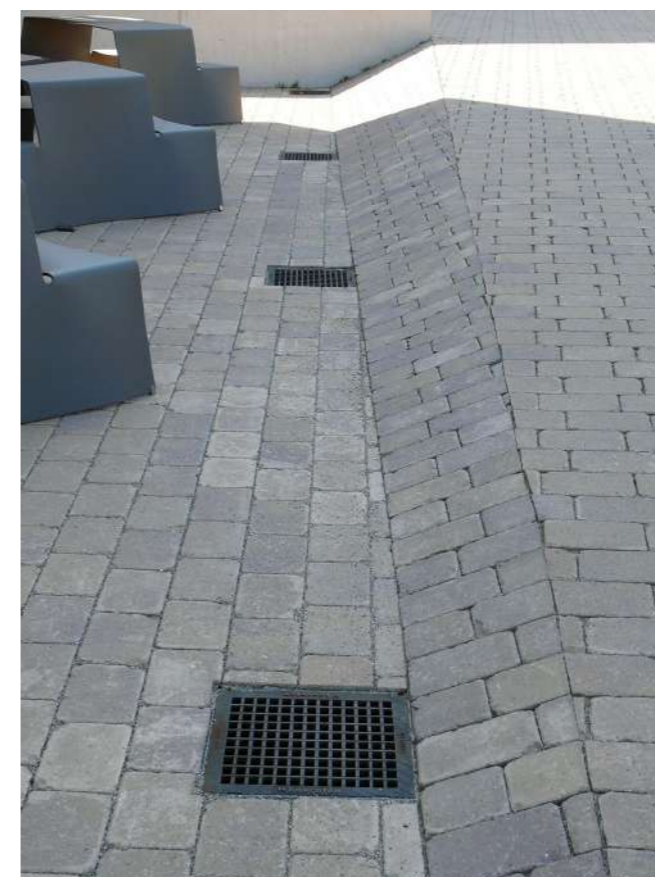

Additional drainage systems

RECYFIX MONOTEC

Highly stable and lightweight - linear drainage made of PP for Civils engineering.

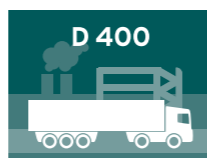

- Parking areas
- Residential areas
- Commercial areas

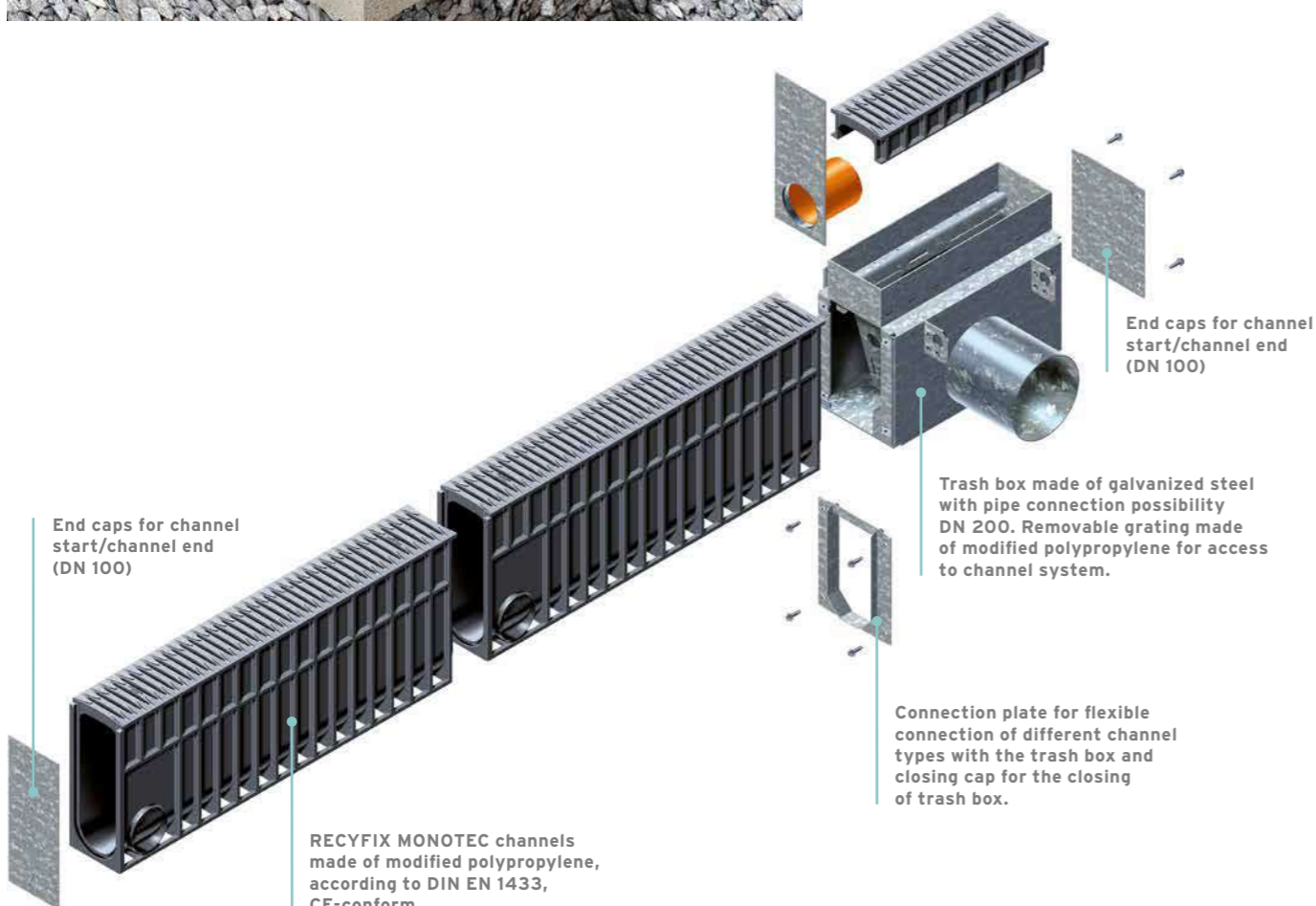

Step Fall adaptors (with the example of RECYFIX MONOTEC)



RECYFIX MONOTEC Step Fall Adapter, black, for channel runs with step fall

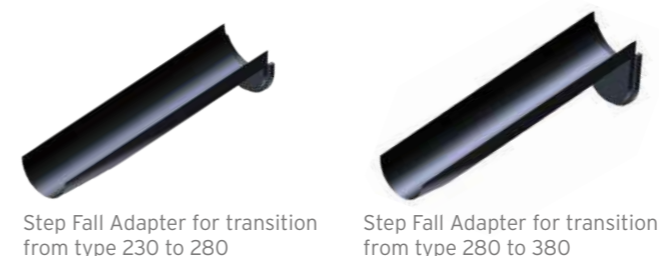

RECYFIX MONOTEC Channel 100:

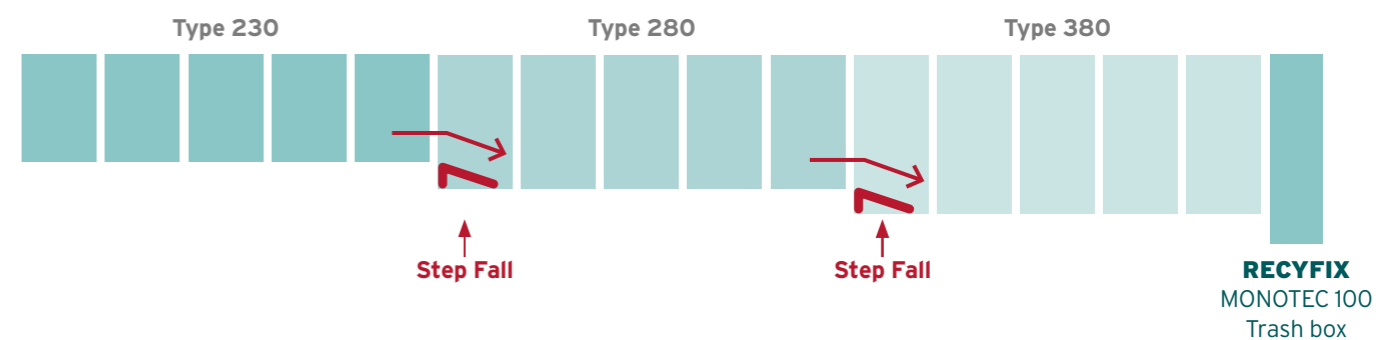

Additional drainage systems

RECYFIX MONOTEC

Highly stable and lightweight - linear drainage made of PP for Civils engineering.

Maximum hydraulic capacity

The fiber-reinforced polypropylene material enables a slim channel design. As a result, a maximum hydraulic capacity is achieved.



NW 100, Type 230



NW 100, Type 280



NW 100, Type 380



NW 200, Type 450

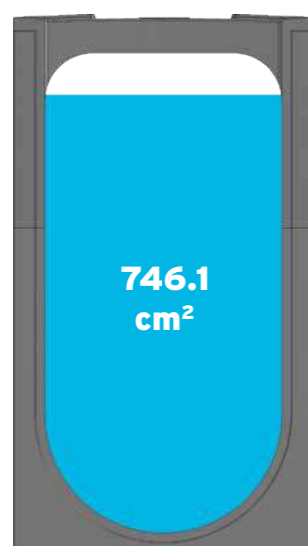

NW 200, Type 450

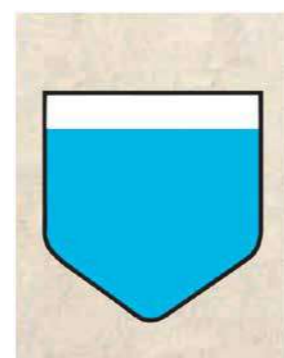

Lower drainage capacity, up to 45 %, with monolithic channels made from other materials



Motorway service Porto Go, Ayuthaya, Thailand



Gardens by the Bay Tadpole Area, Singapore

Additional drainage systems

RECYFIX HICAP F

Drainage- and retention system for larger areas and highest loading capacities up to airports.

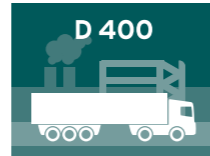
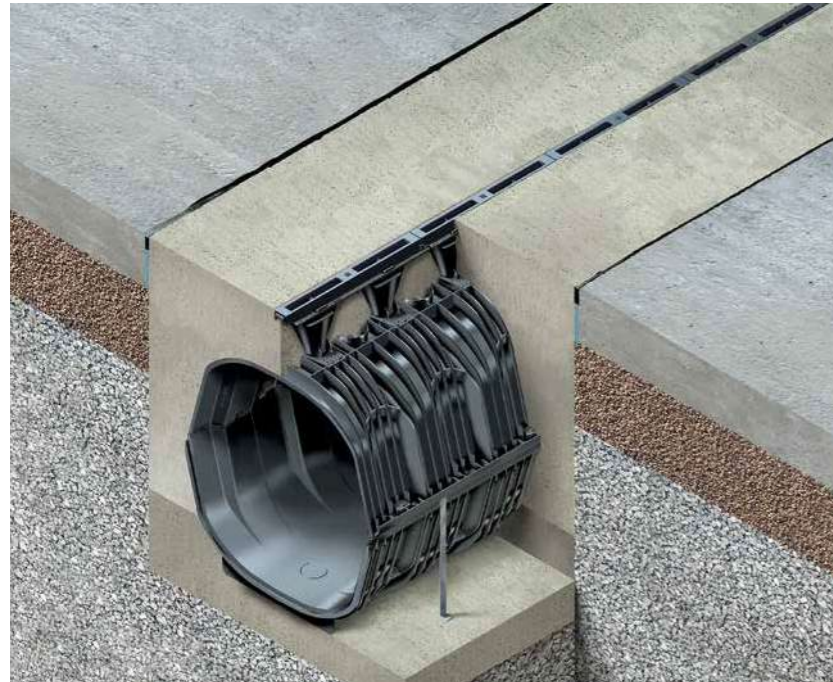

- high capacity drainage channel
 - suitable for heavy load areas
 - no expensive crane or machine hours for installation required

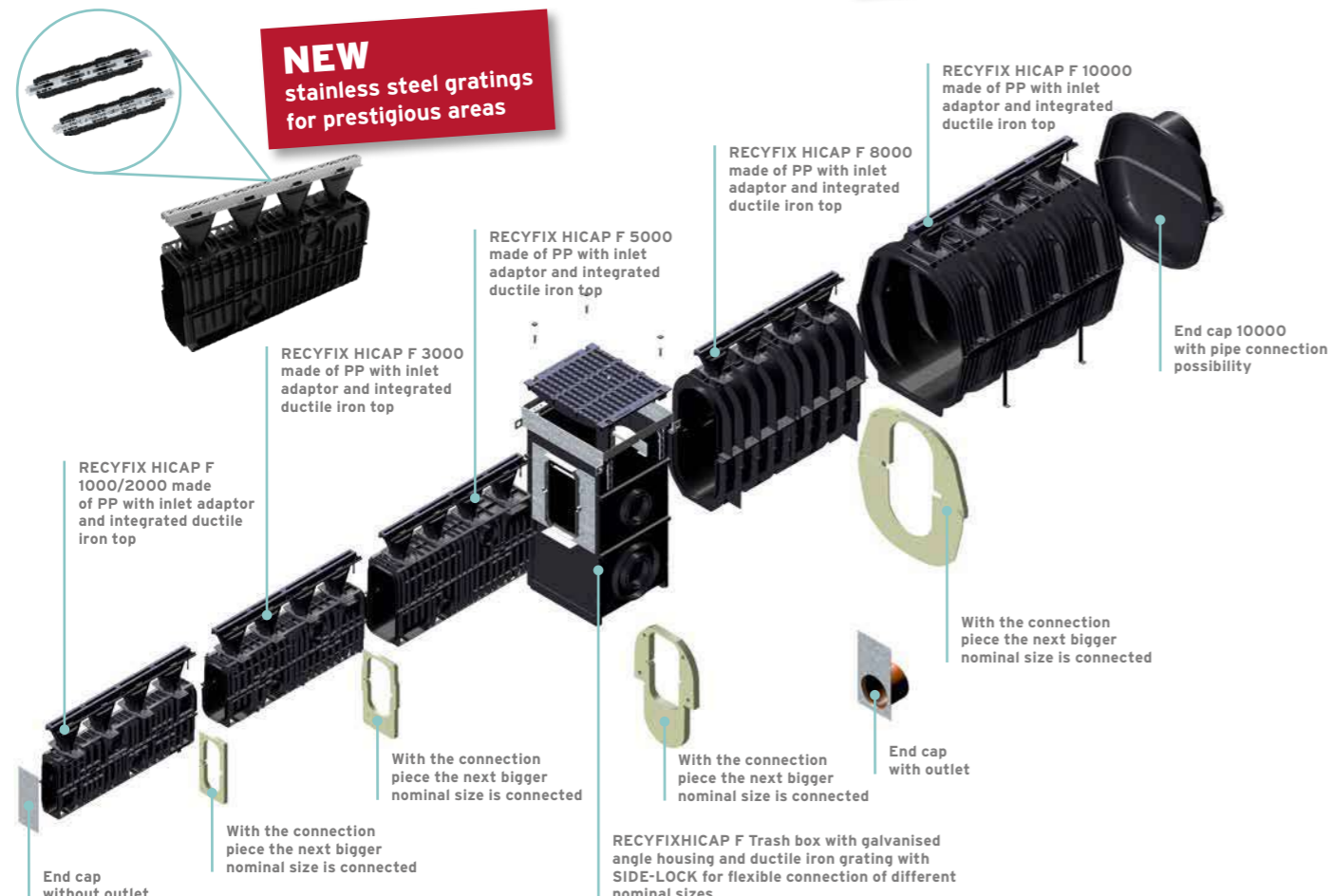

1 Requirements

- Drainage system for extreme conditions with
- high hydraulic requirements
 - high loads
 - large areas
 - ailing sewer systems

2 Application areas

- parking areas
- supermarkets/shopping centres
- pedestrian areas
- airports
- industrial estates
- container terminals
- ports
- circuits and test tracks

3 Solutions

- Special features of RECYFIX HICAP:
- drainage and retention in one component
 - large selection of nominal widths
 - for all loading classes and all common road surface finishes
 - less manholes and outlets
 - provides a uniform visual appearance also in large projects
 - no separate gratings
 - no expensive pipe installations required
 - high hydraulic capacity
 - easy to maintain



International Airport, Bangkok, Thailand

Additional drainage systems

SPORTFIX

The comprehensive range for all Sports Facilities.



- ✓ high quality systems for track and field drainage
- ✓ water jump, longjump, sand traps and soft kerb compliment the product range
- ✓ all products met the IAAF Standards

DRAINFIX TWIN

Infiltration of rainwater on smallest space under car-trafficked areas.

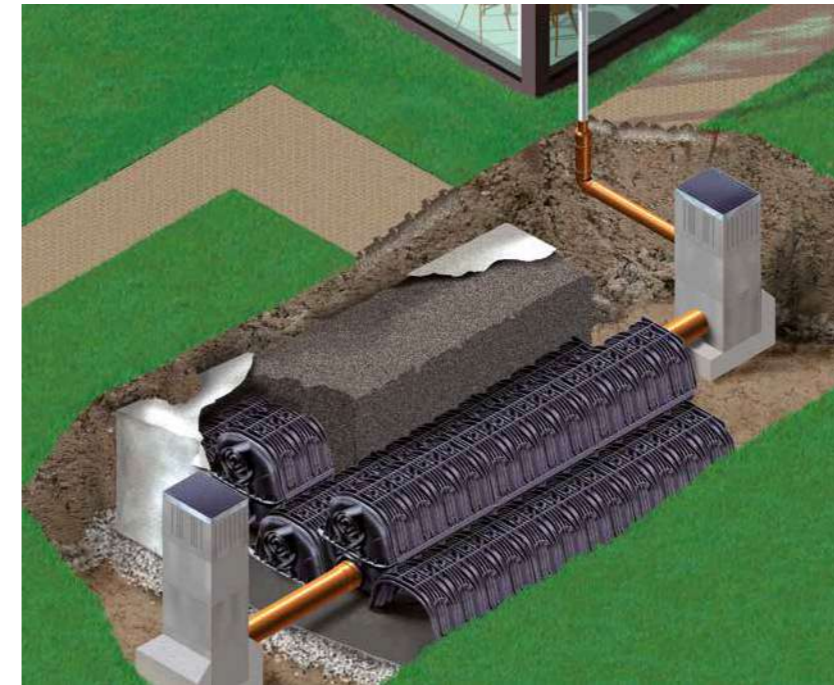

- ✓ very large storage volume
- ✓ flexible installation alignment due to variable combinations
- ✓ combination of seepage and retention possible

DRAINFIX CLEAN

Effective and ecological rain water treatment through filter substratum channel.



- ✓ Drainage and treatment of runoff water in one system
- ✓ excellent treatment effects
- ✓ extremely low maintenance
- ✓ high retention capacity

AQUAFIX Separators

Series „10 PE“ made of polyethylene. Light solutions for strong requirements.

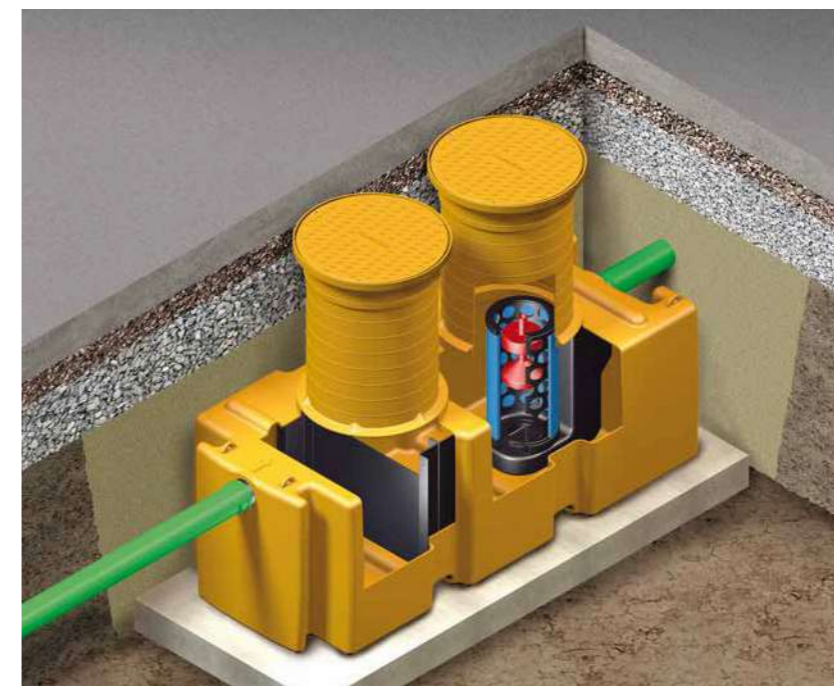

- ✓ 10 mm wall thickness for highest security
- ✓ optimised construction after FE-analysis
- ✓ pure, high quality raw material is used in the optimised production process
- ✓ set for local production available

More information at www.hauraton.com/asia

 **hauraton**

Tersedia di:



QHOMEMART

JL.RAYA JANTI NO.96 YOGYAKARTA
(0274) 493 22 88 , 08112863773 (CHAT ONLY)

f qhomemart t qhomemart @ qhomemart v qhomemart

WWW.QHOMEMART.COM